

Product description

The optical transmitters series OT and the optical receivers series OR are intended to distribute SAT IF and DTT (Digital terrestrial TV) signals through a fibre optic. Transmitters series OT4 convert 4 SAT IF sub-bands into an optical signal. Transmitters series OT5 convert 4 SAT IF sub-bands and DTT band into an optical signals; for converting SAT and DTT bands separate lasers are used. To combine two optical carriers into one single-mode fibre WDM diplexer is used. AGC (automatic gain control) provides for automatically controlled constant load to the laser. Receivers series OR4 convert optical signal into 4 SAT IF sub-bands. Receivers series OR5 convert optical signals into 4 SAT IF sub-bands and DTT band; for converting SAT and DTT bands separate photodiodes and WDM diplexer are used. OLC (optical level control) provides for fixed RF output level at different level of optical input. Receivers with letter **M** (OR401M, OR501MW) have built-in multiswitch (quad outputs). The product is intended for indoor usage only.

Coding explanation of receiver

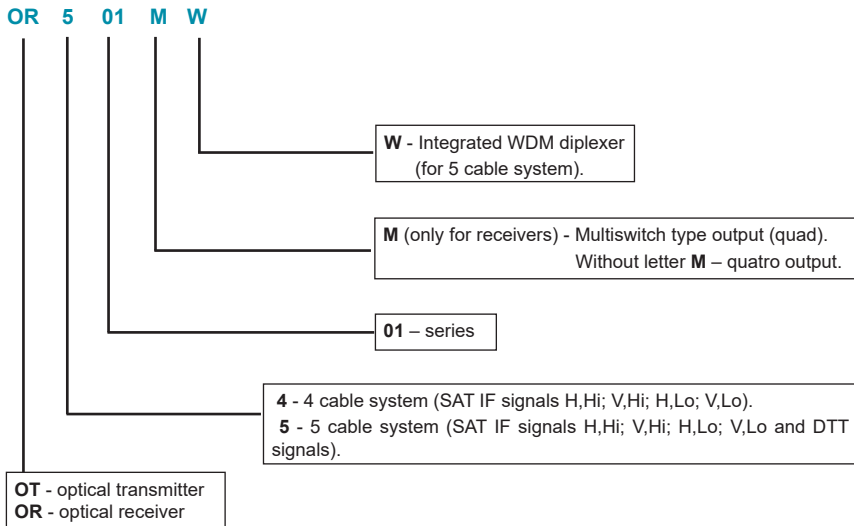

Safety instructions

The equipment must be installed in accordance with IEC 60728-11 and national safety standards. The transmitter is powered from a 12-24 V power supply unit (PSU), the receiver - 12-20 V. This voltage is not dangerous to life. PSU must have a short circuit protection. Any repairs must be done by a qualified personnel. Do not plug the PSU into the mains socket until all cables have been connected correctly. The mains socket of PSU must be easily accessible. To disconnect the equipment power completely, remove the PSU cable from the mains socket. For receivers additionally all RF cables must be disconnected. The equipment must not be exposed to dripping or splashing water. Make sure no liquid filled objects are placed near or on top of the unit. Avoid placing the equipment near heat sources, e.g. central heating components and in areas of high humidity. Keep the equipment away from naked flames. If the equipment has been stored in cold conditions for a long time, bringing it into a warm environment may cause condensation. In such cases let it warm up for at least 2 hours before plugging it into the mains. **IMPORTANT:** Mounting of the equipment is allowed vertical only and the free flow of air through the unit must be not restricted. Always leave 10 cm of free space from the top, front and bottom of the unit to allow heat dissipation.



Safety of laser product

Optical Transmitter module contains laser diode sources. These devices are rated under IEC60825-1:2007 "Safety of Laser Products", Part 1: Equipment classification and requirements as CLASS 1M laser product. When operating the equipment note the following: Most fiber optic laser wavelengths are totally invisible to the eye and will cause permanent eye damage. Never look into the end of a fiber on a powered device through a magnifying device (microscope, eye loupe, magnifying glass, etc.). Before using such devices always double check that power is disconnected or, if possible, completely disconnect the unit from any power source. To verify the light output always use an instrument, such as an optical power meter. Operate only with the proper optical fiber installed in the device optical connector. Whenever the optical connector is empty the laser transmitter should be turned off. Before applying power always connect a fiber to the output of the device. Never leave equipment with radiating bare fibers accessible - always cap the connectors.



INSTALLATION

Requirements for external power supply unit (PSU)

	Transmitter	Receiver
Output voltage range	+12 V min ...+24 V max	+12 V min ...+20 V max
Output current	> 1.5 A	> 0.5 A
Output connector	pin (range 0.5...0.75 mm ²)	type 3.5/1.35 EP (+) plug

- Short circuit protection
- Double insulated (marked )
- Meet EN 55022 class B conducted emissions requirements, measuring with grounded load

Mounting

It is very important to ensure the free flow of air through the units.

Always leave 10 cm of free space from the top, front and bottom of the unit to allow heat dissipation.

Max. ambient temperature: +40° C (for transmitters)

+50° C (for receivers)

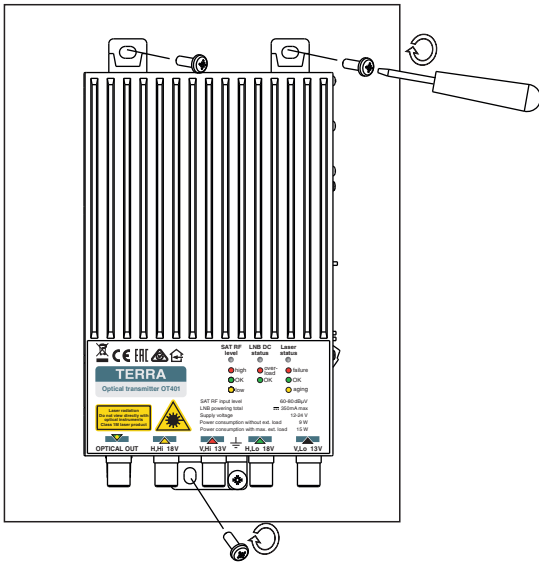

Figure 2. Mounting of the transmitter

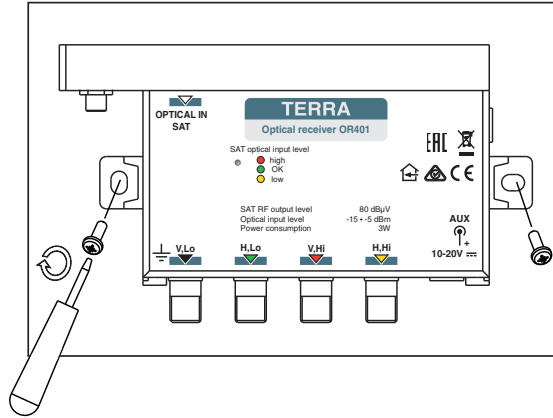

Figure 3. Mounting of the receiver

Transmitters must be fixed with 3 steel screws, receivers – with 2 steel screws Ø 4-4.5 mm.

The screws are not included in a package.

Optical connections

1. Align the FC/APC connector key-way (type R) with the receptacle key-way.

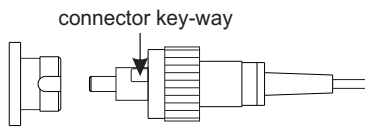

2. Push firmly to locate the key-ways and then rotate the coupling ring.

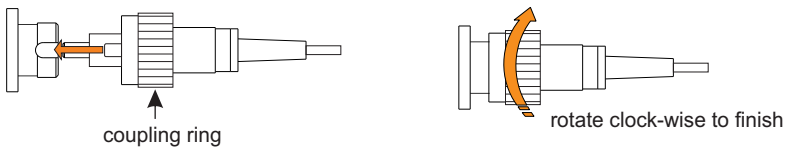

3. During the operation each fiber connector may be contaminated by dust or dirt. Even tiny particles of dust will affect the transmission quality. Dusty fiber optic connector will contaminate other connected optic parts.

If optical reception power of the receiver decrease, fiber connection should be cleaned and maintained.

Always clean all the fiber optic connectors before setting.

Reel cleaners or prepackaged lint free wipes or swabs with alcohol are the most convenient means of cleaning optical connectors.

Fiber connectors should never be left uncovered.

4. Do not exceed the minimum bending radius when connecting optic cable to the system.

External view of the transmitter

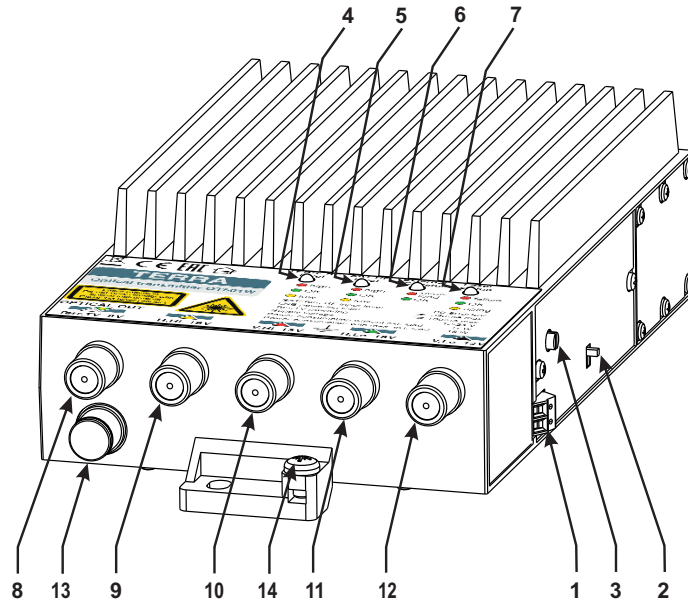
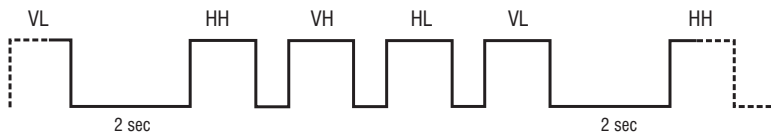

Figure 1. External view of the transmitter

- 1 - +12...+24 V DC powering input. Screw terminal.
- 2 - Switch for Terr.TV preamplifier powering ON/OFF.
- 3 - Switch for selecting appropriate number of terrestrial transponders in your area.
- 4 - LED indicator for Terrestrial RF input level (only for OT501W)
 - red – to high
 - green – correct (AGC range)
 - yellow – to low
- 5 - LED indicator for SAT RF input level.
 - red – to high
 - green – correct (AGC range)
 - yellow – to low

The status of four SAT IF inputs (HH, VH, HL and VL) is shown in next way :



- 6 - LED indicator of LNB and terrestrial preamplifier powering status.
 - red – short circuit occurred or overload on LNB or terrestrial preamplifier
 - green – works correctly
- 7 - LED indicator of laser status.
 - red - laser is damaged
 - green - works correctly
 - yellow - laser ageing
- 8 - RF input of DTT signal, DC output for preamplifier +9 V switchable (only for OT501W). F socket.
- 9 - RF input of SAT IF H,Hi polarity, DC output +18 V. F socket.
- 10 - RF input of SAT IF V,Hi polarity, DC output +13 V. F socket.
- 11 - RF input of SAT IF H,Lo polarity, DC output +18 V. F socket.
- 12 - RF input of SAT IF V,Lo polarity, DC output +13 V. F socket.
- 13 - Optical output. FC/APC socket.
- 14 - Functional grounding clamp.

External view of the receiver without WDM diplexer (OR401, OR401M)

OR401

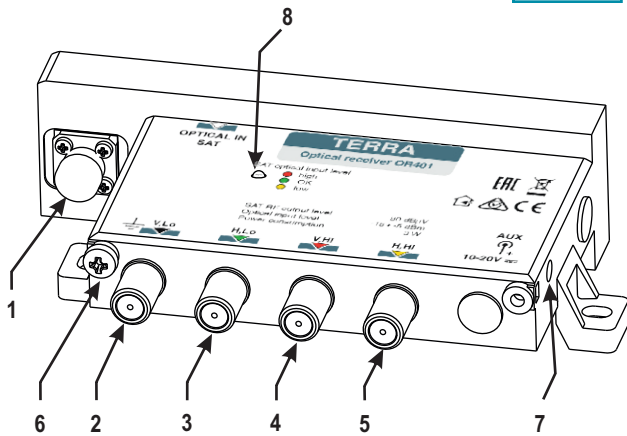

- 1. **OPTICAL IN SAT** - optical input. FC/APC socket.
- 2, 3, 4, 5 - RF outputs of SAT IF. F sockets.

	OR401	OR401M
2	V,Lo	Rec.1
3	H,Lo	Rec.2
4	V,Hi	Rec.3
5	H,Hi	Rec.4

- 6. Functional grounding clamp
- 7. **AUX** - +10...+20 V DC powering input (3.5/1.3 mm DC jack).
- 8. LED indicator of optical input power
 red – to high
 green – correct (AGC range)
 yellow – to low

External view of the receiver with WDM diplexer (OR501W, OR501MW)

OR501W

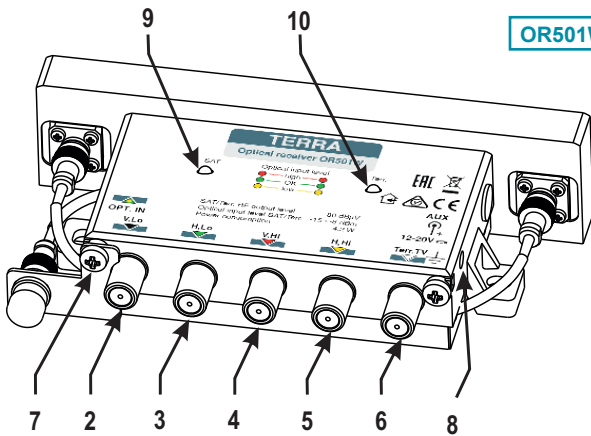

- 1. **OPTICAL IN SAT** - optical input. FC/APC socket.
- 2, 3, 4, 5, 6 - RF outputs of SAT IF and DTT. F sockets.

	OR501W	OR501MW
2	V,Lo	Rec.1 (SAT IF+DTT)
3	H,Lo	Rec.2 (SAT IF+DTT)
4	V,Hi	Rec.3 (SAT IF+DTT)
5	H,Hi	Rec.4 (SAT IF+DTT)
6	DTT	-

- 7. Functional grounding clamp
- 8. **AUX** - +10...+20 V DC powering input (3.5/1.3 mm DC jack).
- 9. LED indicator of optical SAT input power
 red – to high
 green – correct (AGC range)
 yellow – to low
- 10. LED indicator of optical DTT input power
 red – to high
 green – correct (AGC range)
 yellow – to low

Structure diagram OR501W, OR501MW

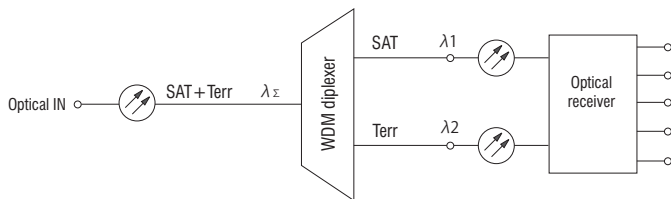

OPERATING AND SETTINGS

General notes

Read the safety instruction first.

All unused optical connectors must be covered with a clean protective caps.

All unused F type connectors must be terminated with 75 Ω loads. SAT IF and DTT inputs on transmitter due to DC voltage must be terminated with 75 Ω loads with DC voltage blocking coupler (VBC).

Before connecting to the receiver, check the optical level of the signal on the optical fibre using an optical power meter. The optical input signal higher than 0 dBm may damage the device. To avoid overload, an optical attenuator must be connected to the input of the receiver.

Powering

For transmitters: connect DC voltage +12...+24 V to the DC powering input. Within 5-30 seconds the module will run in normal operation mode and is ready to work.

Note :If external terrestrial preamplifier is used, switch the Terr.TV preamplifier powering to „ON“. On RF input of DTT signal appears DC voltage +9 V with max load 100 mA (only for OT501xxx).

The receivers can be powered in next ways:

	OR401	OR401M	OR501W	OR501MW
from PSU	10 V...20 V	10 V...20 V	12 V...20 V	12 V...20 V
from set-top box	no	yes	no	yes
from multiswitch	yes	no	yes	no

Note: If supply voltages are < 12 V, but >10 V, DTT RF signal is OFF for all OR501xxx models.

RF input levels to the transmitter

The transmitter has automatic RF gain control (AGC) on every input for constant laser load. This makes configuration much easier.

However, the RF signals at the inputs of transmitter must meet the following requirements:

SAT

RF level at the input must be 60...80 dBμV per transponder for 30 transponders (75...95 dBμV total power); in this range AGC works correctly.

DTT

To ensure an optimal operating of the optical transmitter, the DTT input signals should be adjust at the same high level.

RF level at the DTT input must be 60...80 dBμV per transponder for 8 transponders (69...89 dBμV total power); in this range AGC works correctly.

The number of DTT channels may be not the same at different areas. To achieve the same output level at receiver output, the switch for selecting number of DTT channels is used. It allows to keep constant output level at the receiver by changing number of DTT transmitters from 1 to 8. At higher number of transmitters the output level is decreasing.

Below some reference level values (for receivers with quatro output) are given to show how the switch is functions; output levels of receivers with quad output (with letter „M“, e.g. OR401M) are 5 dB lower.

Number of ch.	Switch position				
	1	2	4	6	8
1	80 dBμV	83 dBμV	86 dBμV	88 dBμV	89 dBμV
2	77 dBμV	80 dBμV	83 dBμV	85 dBμV	86 dBμV
4	74 dBμV	77 dBμV	80 dBμV	82 dBμV	83 dBμV
6	72 dBμV	75 dBμV	78 dBμV	80 dBμV	81 dBμV
8	71 dBμV	74 dBμV	77 dBμV	79 dBμV	80 dBμV
16	68 dBμV	71 dBμV	74 dBμV	76 dBμV	77 dBμV

Note, that all above given RF levels values are approximate, supposing that all channels levels are equalised, and frequency response of equipment is ignored.

Optical input level to the receiver

The operational optical input level of the receiver is -15...-5 dBm. In this region OLC (optical level control) is working and provides for fixed RF output levels. The optical output level from transmitter is 6dBm. It means, that possible optical attenuation range from transmitter to receiver is 11...21 dB.

RF output levels from the receiver

The receiver has optical level control (OLC), which allows to have a fixed level of RF output signals at different level of input optical signal. OLC range is -15...-5 dBm. RF output level remains constant while optical input power fluctuates in mentioned region. However, RF output level depends on number of transmitted signals through the fibre.

SAT

The RF signal level at receiver SAT outputs depends on RF signal level at transmitter inputs and optical input power at receiver input. By typical application conditions

RF level at the transmitter input 60...80 dB μ V per transponder (75...95 dB μ V total power).

Optical input level at the receiver -15...-5 dBm.

Output RF levels of the receiver are:

Receiver with quatro outputs (without letter **M** (OR401, OR501W)) - typ. 80 dB μ V.

Receiver with quad outputs (with letter **M** (OR401M, OR501MW)) - typ. 75 dB μ V.

DTT

The RF signal level at receiver DTT output depends on RF signal level at transmitter input, optical input power at receiver input and number of channels. By typical application conditions

RF level at the transmitter input 60...80 dB μ V per transponder (69...89 dB μ V total power).

Optical input level at the receiver -15...-5 dBm.

Number of channels 8.

Output RF level of the receiver is:

Receiver with quatro outputs (without letter **M** (OR501W)) - typ. 80 dB μ V.

Receiver with quad outputs (with letter **M** (OR501MW)) - typ. 75 dB μ V.

If the actual number of channels is not 8, set the switch on transmitter in appropriate position (see description with table above).

Technical specifications

Type	OT401	OT501W
Satellite inputs		
Number of inputs	4	
Bandwidth	950-1950 MHz (VLo, HLo); 1100-2150 MHz (VHi, HHi)	
Input return loss / impedance	> 10 dB / 75 Ω	
RF input level (AGC range) for 30 transponders	60-80 dB μ V (per transponder); 75-95 dB μ V (total level)	
LNB feeding	V,Lo and V,Hi - 13.5 V; H,Lo and H,Hi - 18 V; 350 mA total	
Terrestrial input		
Bandwidth	-	47-862 MHz
Input return loss / impedance	-	> 10 dB / 75 Ω
RF input level (AGC range) for 8 transponders	-	60-80 dB μ V (per transponder) 69-89 dB μ V (total level)
Number of transponders (switchable)	-	1...16
Preamplifier feeding (switchable)	-	9 V 100 mA max.
Optical output		
Wavelength SAT & Terr	1310 nm	1310 nm SAT & 1550 nm DTT
Optical output power	6 dBm	6 dBm SAT; 6 dBm DTT
Optical return loss	> 45 dB	
Laser type	FP	
Main characteristics		
Supply voltage	12 V - 24 V	
Power consumption without external load	9 W max.	11 W max.
Power consumption with max. external load	15 W max.	18 W max.
Operating temperature range	-10 \div + 40 $^{\circ}$ C	
Dimensions/Weight (packed)	108x190x54 mm/1.44 kg	

Technical specifications

Type	OR401	OR401M	OR501W	OR501MW
Optical input				
Optical wave length	1100 - 1650 nm*			
Optical input level (OLC range)	-15...-5 dBm			
Optical return loss	> 40 dB			
RF outputs				
Number of outputs	4	4	5	4
Bandwidth	950...1950 MHz VLo, HLo 1100...2150 MHz VHi, HHi	950...2150 MHz	950...1950 MHz VLo, HLo 1100...2150 MHz VHi, HHi 47...862 MHz DTT	47...790 MHz, 950...2150 MHz
Return loss / impedance	> 10 dB / 75 Ω			
DTT RF output signal level for 8 transponders (optical -5 ÷ -15 dBm)	-	-	80 ± 2 dBμV	75 ± 2 dBμV
SAT IF output level for 30 transponders (optical -5 ÷ -15 dBm)	80 ± 2 dBμV	75 ± 2 dBμV	80 ± 2 dBμV	75 ± 2 dBμV
Output SAT IF control	-	14/18 V, 0/22 kHz	-	14/18 V, 0/22 kHz
Powering				
Supply voltage range	DC AUX	10...20 V		12...20 V
	SAT IF output	10...20 V	13/18 V	10...20 V**
Power consumption	3 W max.		4.2 W max.	
Main characteristics				
Operating temperature range	-20 ÷ + 50 °C			
Dimensions/Weight (packed)	145x86x37 mm/0.42 kg		158x86x37 mm/0.50 kg	

* for receivers with WDM diplexer, depends on diplexer type

** when < 12 V DTT is OFF



INVISIBLE LASER RADIATION DO NOT VIEW DIRECTLY WITH OPTICAL INSTRUMENTS.

Wave length 1270-1610 nm, IEC60825-1:2007



This product complies with the relevant clauses of the European Directive 2002/96/EC. The unit must be recycled or discarded according to applicable local and national regulations.



Equipment intended for indoor usage only.



Functional grounding. Connect to the main potential equalization.



This product is in accordance to following norms of EU: EMC norm EN50083-2, safety norm EN60065 and RoHS norm EN50581.



This product is in accordance with Custom Union Technical Regulations: "Electromagnetic compatibility of technical equipment" CU TR 020/2011, "On safety of low-voltage equipment" CU TR 004/2011.



This product is in accordance with safety standard AS/NZS 60065 and EMC standards of Australia.

Application diagrams

- ① Application example of SAT TV and DTT distribution up to 32 receivers.

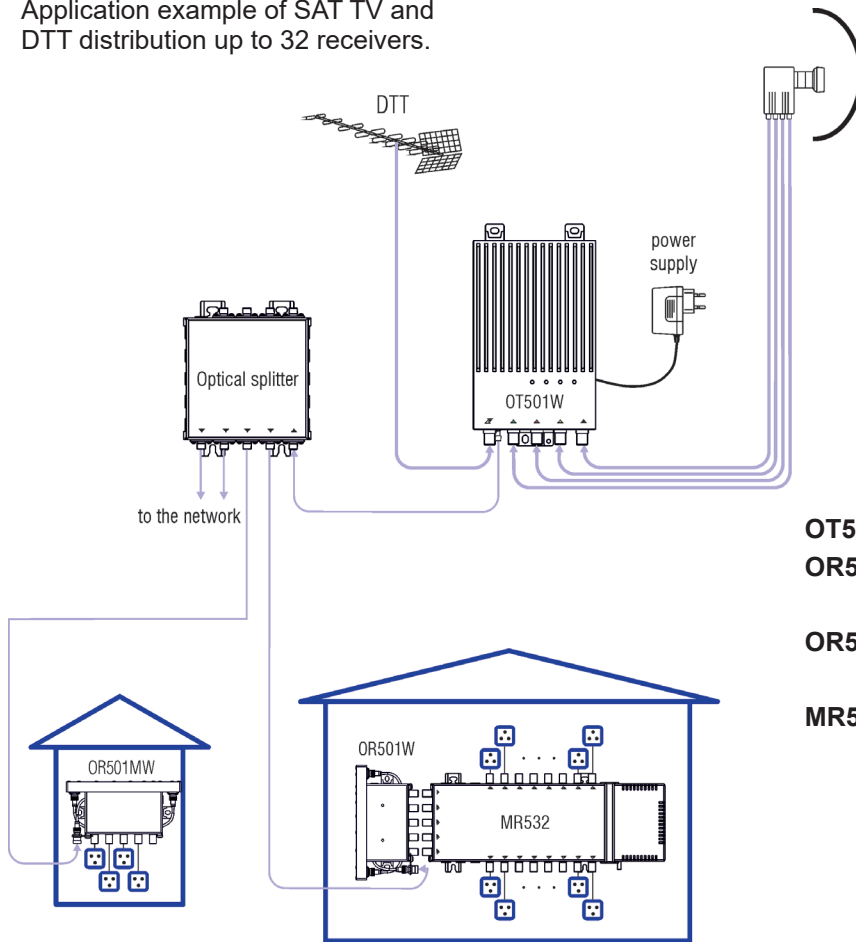

OT501W - optical transmitter
OR501W - optical receiver, virtual quatro, with WDM diplexer
OR501MW - optical receiver with 4x4 multiswitch and WDM diplexer
MR532 - 5x32 multiswitch

- ② Application example of 1 SAT TV distribution up to 32 receivers.

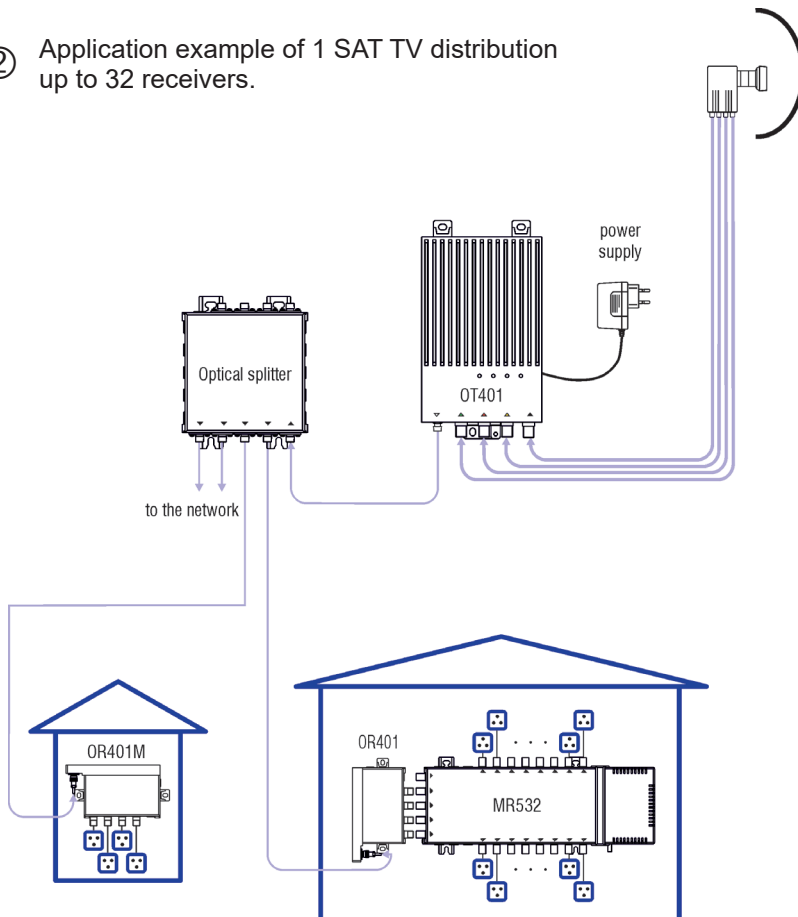

————— coaxial cable
 ————— fiber cable

OT401 - optical transmitter
OR401M - optical receiver with 4x4 multiswitch
OR401 - optical receiver, virtual quatro
MR532 - 5x32 multiswitch